

Interfacing Telephony Signals to SigLab™

It is often necessary to perform measurements on analog telephone lines. The SigLab® differential inputs make it easy to interface to these lines. This application note describes one approach to constructing this interface.

Overview

Typical Telephone Signal Characteristics

Analog telephone lines have a wide range of signal levels. During the ring period, signals of 130 V peak are present. Voice levels are on the order of a few hundred mV peak-to-peak riding on approximately 10 V of DC offset. The telephone line is balanced with a nominal 600 ohm impedance, therefore requiring differential voltage measurements.

SigLab Signal Conditioning Features

The standard SigLab input full-scale range is ± 10 V. An access hatch in SigLab's top cover allows the user to install custom signal conditioning circuitry.

Opening the access hatch exposes two 14-pin dual-in-line headers (one for each channel) with three resistors connected as shown in Figure 1. These headers are behind the input BNC connectors. SigLab's input is a differential type with a 1 Mohm differential input impedance.

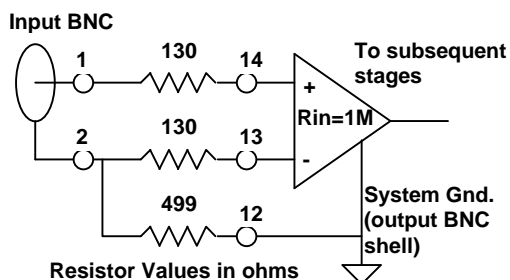

Figure 1 - Standard Input Conditioning

Line to Input / Output Coupling

A Differential Voltage Divider

Given the signal levels and impedances previously mentioned, a passive voltage divider will do the job. Replacing the two standard resistor configurations (assuming a 2-channel interface) with the configuration shown in Figure 2 provides an 11:1 attenuation.

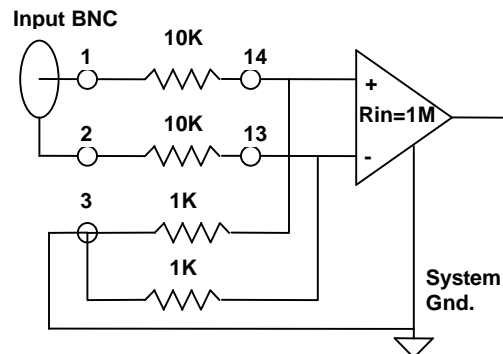

Figure 2 - Telephony Input Conditioning

Several points should be noted:

- 1) The 11:1 scale factor may seem odd (10:1 more natural), but the 11:1 scaling is handled easily by way of the engineering units in the VI software. This attenuation provides a full-scale capability of ± 110 V. The system actually works fine to the 130 V levels encountered on the line due to the extra margin built into SigLab's front end.
- 2) The 22 Kohm differential input impedance is more than sufficient for telephony work given the nominal 600 ohm line impedance.
- 3) The accuracy and common mode rejection are a function of the resistor

tolerances. For best results, use 1% or better resistors.

A Transformer for the Output

Providing a signal to the telephone line is slightly more complicated. Normally the system (PC and SigLab) ground path is via the SCSI cable to the host computer and then to "ground" via the usual safety ground conductor in the power cord. One solution is to eliminate this ground path by running a notebook PC and SigLab from battery power. A better method is to use a telephone coupling transformer with a 1:1 turns ratio.

The objective is to provide a stimulus to the telephone line for a transfer function measurement. The precise characteristics of the transformer (turns ratio, loss, frequency response, etc.) are not critical since the stimulus will be monitored after the transformer.

Figure 3 shows the connections to the coupling transformer along with a 560 ohm series resistor providing an AC source impedance of approximately 600 ohms. A fine choice for the transformer, among many others, is the Stancor type TTPC-1, -2, -6, or -7 (available from Newark Electronics).

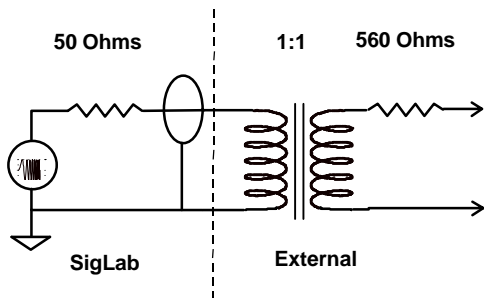

Figure 3 - Output Interface

Making Measurements

Engineering Units for Scaling

The **vos**, **vsa**, **vna** and **vid** virtual instruments support engineering units. Using the engineering units allows the proper scale factors for the input to be applied to the

displayed data. These factors are also stored with the measurement data in the appropriate file.

On/ Off-Hook

If the impedance presented to the line is high (e.g. 22K ohms) the line does not "see" this loading and behaves as though the line is inactive (the telephone is on the hook). This is useful for making non-intrusive measurements.

If an impedance of 600 ohms is connected to the line, the line goes to the off-hook state and behaves as though the telephone handset has been lifted from the cradle. A dial tone signal is created when the line goes from the on-hook to off-hook state.

A Measurement Example

Figure 4 shows a typical electrical measurement configuration for a 2 channel measurement, including coupling a source to the line. SigLab's 2 input channels are assumed to be configured as in Figure 2.

This configuration allows both single channel measurements (power spectrum or time-domain), as well as a 2 channel transfer function measurement.

Two telephone lines are connected to SigLab input channels, and Line 1 is coupled to the output generator. A standard telephone is also connected to the lines. A single-line phone will suffice, but with a two line phone transfer function measurements can be made for calls in both directions.

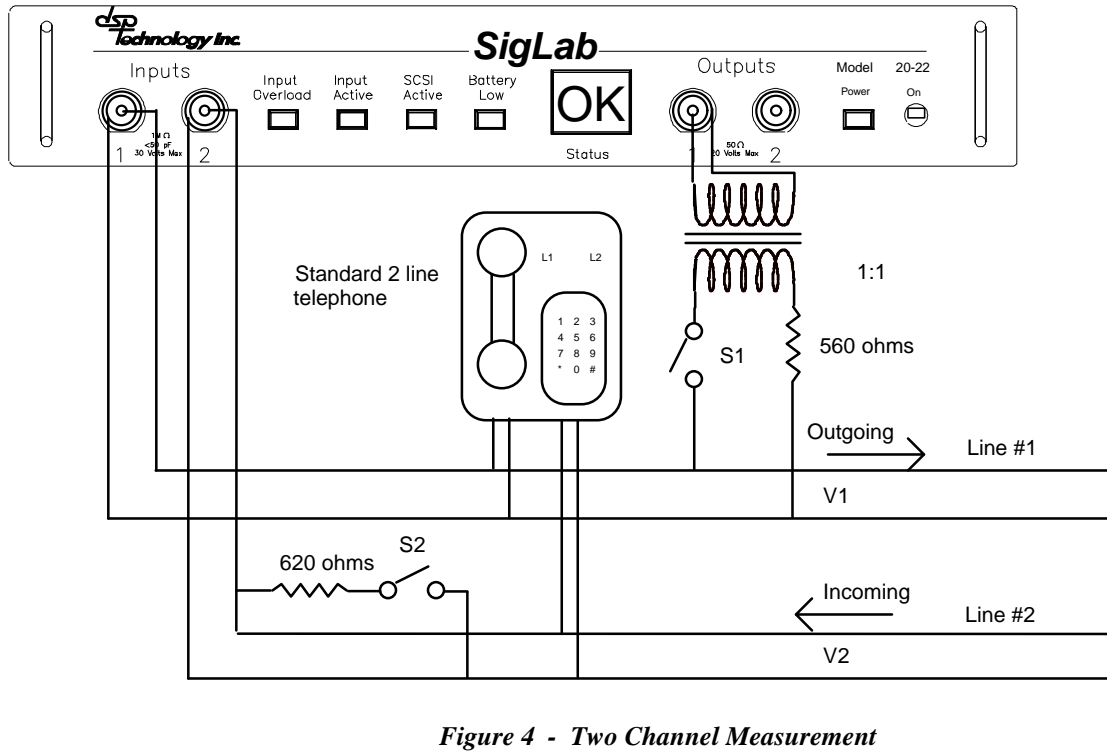

Figure 4 - Two Channel Measurement

The following steps are taken to set up for the transfer function measurement:

1. Open S1 and S2.
2. Select line 1 with the telephone.
3. Pick up the handset, and dial line 2's number.
4. When line 2 rings, close S2.
5. Close S1, and hang up the handset.

Telephone lines 1 & 2 are now connected through the local switching office. The transfer function of the circuit (through the telephone office) can be measured now.

Frequency Response

An interesting measurement is the frequency response of a station-to-station call.

SigLab has three different virtual instruments for measuring the frequency response of a linear system:

1. **vna**: network analyzer (FFT based).
2. **vss**: network analyzer (swept sine).
3. **vid**: system identification.

The signal to noise ratio and linearity of the telephone system make the **vna** a good choice for this measurement.

Figure 5 shows the setup and resulting frequency response measurement of the **vna**. For a power spectral or a time domain measurement we would need to turn engineering units on to account for the attenuators. However for this transfer function the engineering units are not needed since the attenuation is the same on both channels.

A chirp excitation serves as the stimulus to the system. The chirp contains energy throughout the selected analysis band of DC to 5 kHz. It is injected into line 1 via the transformer. Note that channel 1 is connected directly across line 1 to monitor the excitation. The frequency response of the transformer therefore does not affect the

measurement. The measurement provides the relationship of V2 to V1.

The measurement reveals a 16 dB loss at approximately 300 Hz and a roll-off of 12 dB more at 3 kHz. This leads to an ultimate attenuation of 28 dB at the 3 kHz band edge.

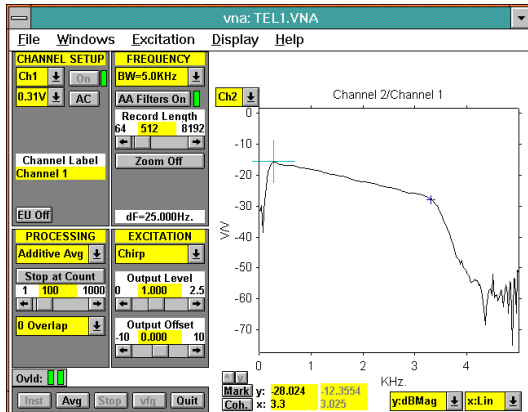

Figure 5 - Frequency Response

Figure 6 shows both the magnitude and phase of the line transfer function plotted with a log x-axis (Bode plot). The plot was captured using the Windows Metafile format in the **vna** and then imported directly into this document. The Metafile format provides the best graph quality.

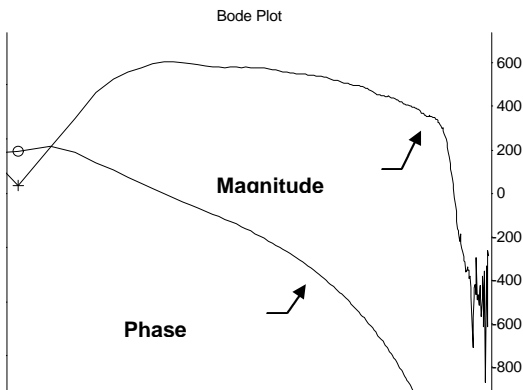

Figure 6 - Telephone Line Bode Plot

Conclusion

This note describes how to interface SigLab's inputs and outputs to standard analog telephone lines. As a measurement example, the vna (network analyzer) is used to characterize station to station transmission properties. Many other measurements are possible with the SigLab / MATLAB combination including:

- Group delay.
- Line modeling (differential equations).
- Line impedance.
- Noise and distortion.
- Cross talk.
- Transient response.
- Long record excitation and response.

These measurements provide a means to fully characterize a typical telephone connection.

For more information contact:

Spectral Dynamics

1010 Timothy Drive

San Jose, CA 95133-1042

Phone: (408) 918-2577

Fax: (408) 918-2580

Email: siglabsupport@sd-star.com

www.spectraldynamics.com